

SOLENOID VALVE

Type S6N

Port Size 5mm (3/16")

FOR AMMONIA, R12, R22, R502

AND OTHER COMMON REFRIGERANTS

FEATURES

- Standard Coil Housing Meets NEMA 3R and NEMA 4 - Rain Tight
- Coil Housing Surpasses NEMA Salt Spray Test
- Plunger-Needle Assembly Same for S4A, S5A, S8F, S6A
- Replaceable PTFE Seat
- Molded Class "B" Coil Construction
- Same Coil Fits All Refrigerating Specialties Solenoid Valves
- Pilot Light Available
- Stainless Steel Needle
- Manual Opening Stem
- MOPD and MRP 27.6 bar (400 PSIG)

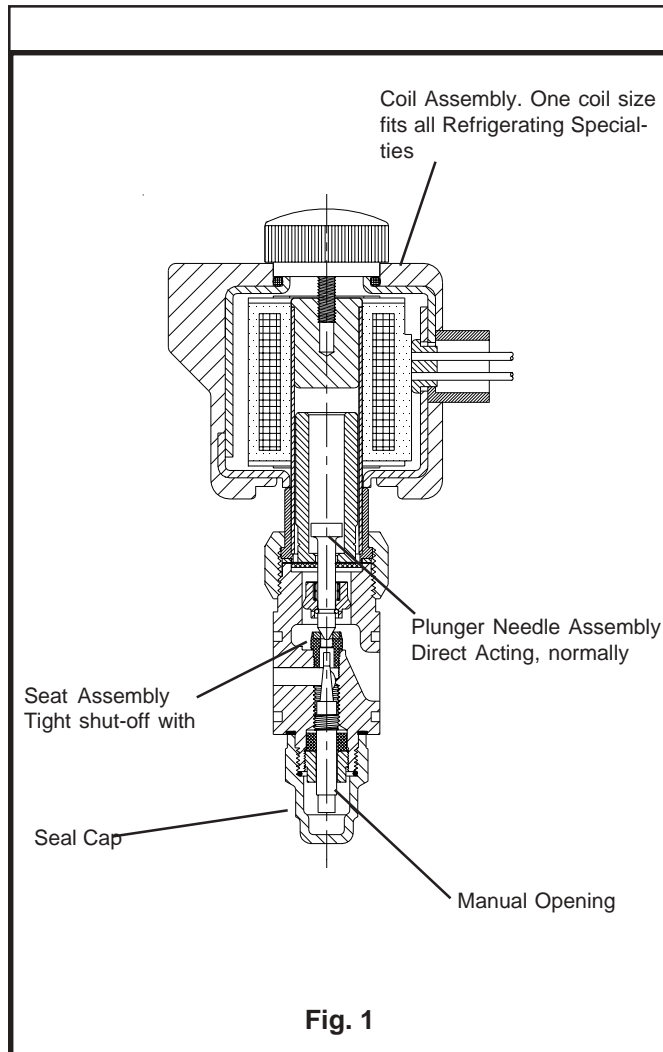

BULLETIN 30-90F

Type S6N



February 2003

Installation, Service and Parts Information

Description

This compact, heavy duty, direct acting, plated ductile iron bodied Solenoid valve is suitable for Ammonia, R-12, R-22 R-502 and other common refrigerants for liquid lines, refrigerant oil lines, and as a pilot valve to actuate remote gas powered valves and other pilot actuated devices. The plunger-needle assembly is also used with most other Refrigerating Specialties Industrial Solenoid Valves. This valve is usually ordered with a close-coupled stainless steel screen strainer. (See current Bulletin 00-10 for strainer information.)

Purpose

A solenoid valve is an electrically operated device used to control the flow of liquids or gases in a fully open or fully closed configuration. The S6N is a normally closed solenoid valve to control the flow of refrigerant. Like all Refrigerating Specialties Solenoid Valves, this valve does not modulate. When electrically energized, it opens wide; when de-energized, the valve closes to stop flow in the normal direction.

This valve is direct acting; the valve needle is lifted and held open electrically by the solenoid coil. No pressure drop or flow is required to open or hold open this valve. Thus, the S6N Solenoid Valve is ideal for use as a pilot solenoid valve. Although too small for suction line applications in most cases, the S6N is often used as a pilot solenoid valve to actuate gas powered valves in suction lines. This valve can also automatically stop liquid flow to thermal expansion valves, float valves or hand expansion valves.

Principles of Operation

This is a normally closed direct operated solenoid valve. When the solenoid is energized, the plunger needle assembly is lifted up and held open mechanically by the pull of the solenoid coil. Consequently, the S6N will open and remain open with no pressure drop across the valve or flow through the valve.

Operation is as follows: Starting with a closed valve; when energized, #6 Solenoid Coil forms a magnetic field which pulls #9 Plunger-Needle Assembly upward pulling it up and away from its #10 Seat Assembly to permit fluid travel through the valve. When de-energized, the spring in the #9 Plunger-Needle-Assembly forces the valve closed.

Manual Opening

To manually open the S6N Solenoid Valve, cautiously remove #17 seal cap and turn #12 Manual Opening Stem in (clockwise viewed from beneath.) The rising stem will lift the valve needle from its seat and permit flow. To resume automatic operation, turn #12 Manual Opening Stem out (counter-clockwise viewed from beneath) until it stops and replace #17 Seal Cap.

Repair Kits For Type S6N Solenoid Valve

Item	Description	Qty.	Kit Number
1	Knob	1	Only Available With Kit
3	O-Ring	1	Only Available With Kit
1, 3	Knob Kit	1	205237
6	Coll	1	
7	Tube Assembly, Solenoid	1	Only Available With Kit
8	Gasket	1	Only Available With Kit
7-8	Tube Kit, Solenoid	1	201036
9	Plunged Needle Assembly	1	Only Available With Kit
10	Seat Assembly	1	Only Available With Kit
8-10	Plunger/Seat Kit*	1	201630
9	Plunger/Noodle Assembly	1	Only Available With Kit
8-9	Plunger Kit, Needle**	1	201019
11	Body, S6N (includes Name Plate)	1	Not Available Separately
12	Stem, Manual Open	1	Only Available With Kit
13	Washer, Flat	1	Only Available With Kit
14	Packing, Stem	1	Only Available With Kit
15	Nut, Packing	1	Only Available With Kit
12-15	Stem Kit, Opening	1	201631
13	Washer, Flat	1	Only Available With Rit
15	Nut, Packing	1	Only Available With Kit
14	Packing, Stem	1	Only Available With Kit
13-15	Packing Kit, Stem	1	202100
16	Gasket	1	Only Available With Kit
17	Seal Cap	1	Only Available With Kit
16-17	Cap Kit, Seal	1	202713
18	Flange Kit (Specify Flange Style & Connection Size) Includes 2 Flanges Only. Sold Separately	1	FK-13
19	Bolt	2	Only Available With Kit
20	Nut	2	Only Available With Kit
21	Gasket Package	12	202078
19-20	Bolt Kit (S6N Without Strainer)	1	201579
19-20	Soft Kit (S6N With Strainer)	1	201576
8,16,21	Gasket Kit (includes 2 Flange Gaskets)	1	201632

* For AC only. Part No. 202102 for DC only.

** For AC only. Part No. 201021 for DC only.

Dimensional Data

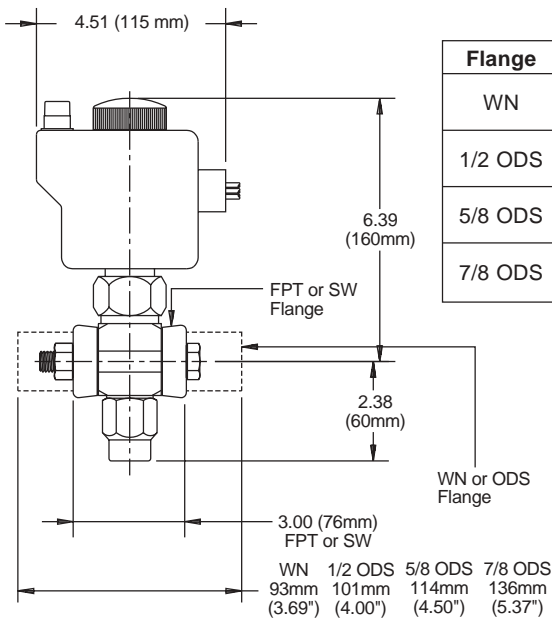

S6N Without Strainer

Flange	A	B
WN	144mm 5.69"	46mm 1.81"
1/2 ODS	152mm 6.00"	50mm 1.97"
5/8 ODS	165mm 6.50"	56mm 2.22"
7/8 ODS	187mm 7.37"	67mm 2.66"

Allow 100mm (4") above valve for removal of coil housing and coil.
Allow 25mm (1") below valve to operate manual opening stem.

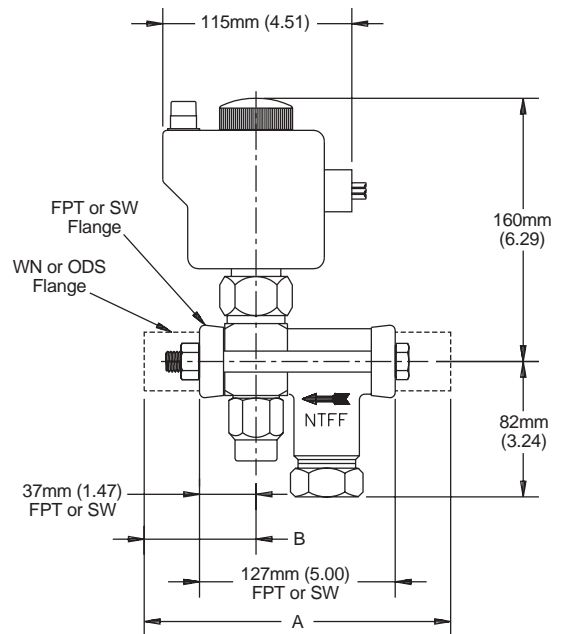

S6N With Strainer

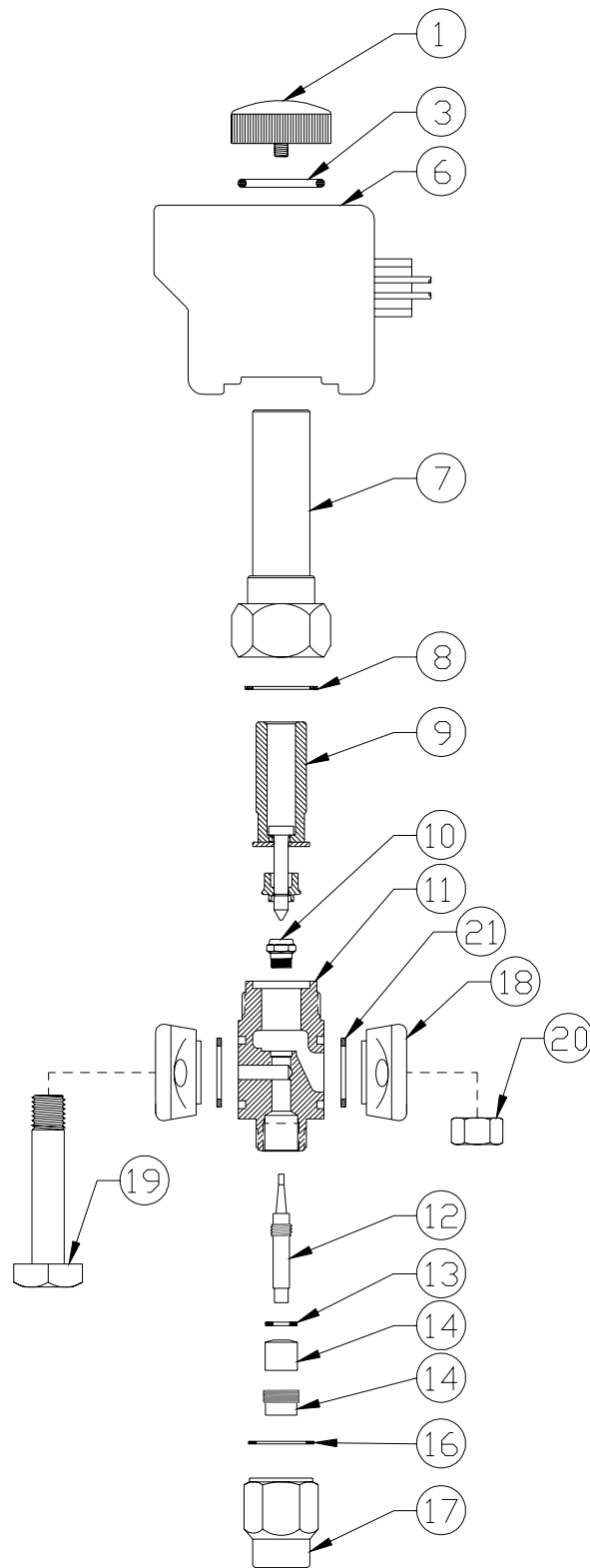

Installation

Protect inside of valve from dirt, chips and moisture during installation. Mount only in horizontal pipe line with solenoid coil at the top; this valve will work properly only in this position. In a liquid line the Solenoid Valve should be near the expansion valve inlet. It is advisable to install the S6N's close coupled companion strainer ahead of the valve for protection against dirt and chips.

The S6N solenoid valve must be installed with the arrow on the valve body in the direction of flow through the valve. If the valve is backwards, the flow will not be stopped when the valve is electrically de-energized. Like all Solenoid Valves, the S6N can stop flow only in the direction from normal inlet to normal outlet (as shown by the arrow on the body). If reversal of pressure occurs in the system so the outlet pressure exceeds the inlet pressure by more than 1.7 Bar (25 psi) the valve needle will be blown upward from its seat and reverse flow will occur. If a system has this type of pressure reversal (as encountered during hot gas defrost with liquid recirculation systems). A check valve such as Refrigerating Specialties Division Type CK4A in series with the solenoid valve will prevent flow reversal. (CK4A must be installed downstream to avoid trapping liquid.)

Electrical

The Refrigerating Specialties Division molded water resistant Class "B" solenoid coil is designed for long life and powerful opening force. The standard coil housing meets NEMA 3R and 4 requirements. This sealed construction can withstand direct contact with moisture and ice. The coil housing far exceeds the requirements of NEMA Standard ICS, 1-110.57 salt spray test for rust resistance.

By definition, Class "B" coil construction will permit coil temperatures, as measured by resistance method, as high as 130°C (266°F). Final coil temperatures are a function of both fluid and ambient temperatures. The higher fluid temperatures require lower ambient temperatures so the maximum coil temperature is not exceeded. Conversely, low fluid temperatures permit higher ambient temperatures.

The molded Class "B" coil is available from stock with most standard voltages. However, coils are available for other voltages and frequencies, as well as for direct current. Coils are also available as transformer type with a 6 volt secondary winding for use with the Refrigerating Specialties Division Pilot Light Assembly (see current copy of Bulletin 60-10, "Pilot Light Assembly and Solenoid Transformer Coil").

The solenoid coil must be connected to electrical lines with volts and Hertz same as stamped on coil. The supply circuits must be properly sized to give adequate voltage at the coil leads even when other electrical equipment is operating. The coil is designed to operate with line voltage from 85% to 110% of rated coil voltage. Operating with a line voltage above or below these limits may result in coil burnout. Also, operating with line voltage below the limit will definitely result in lowering the valve opening pressure differential. Power consumption during normal operation will be 33 watts or less.

Inrush and running current is listed below:

Standard Coil Volts/Hertz	Inrush Current (Amps)	Running Current (Amps)	Fuse Size (Amps)
120/60 (Blue leads)	1.18	0.46	1
208/60 (Blue & Red leads)	0.63	0.26	1
240/60 (Red leads)	0.60	0.23	1
440/60 (Yellow & Red leads)	0.39	0.13	1
115/50 (Yellow & Blue leads)	1.22	0.21	1
230/50 (Yellow leads)	0.65	0.26	1
Other	(Contact Factory)		

On transformer coil the 6 volt leads are always black.

Service Pointers

The S6N Solenoid Valve (and strainer) are easily removable for cleaning or repairing. To remove valve and strainer, first manually open the valve and pump out the refrigerant in the section of the line sealed off. Then unscrew the flange bolts and spread the flanges slightly apart.

1. Failure to open: (a) Coil is of incorrectly high voltage. See "Electrical". Check voltage printed on coil. (b) Line voltage is abnormally low. See "Electrical". Check line voltage with coil energized at coil lead with a voltmeter. (c) Failure to electrically energize. Check control circuit. (d) Pressure exceeds a maximum pressure difference across the valve of 20.7 Bar (300 psi). (e) Solenoid coil is burned out. See "Electrical" and replace with proper coil. (f) Plunger may be jammed with dirt. Inspect as in

(2b) below. (g) Damaged bonnet-tube due to excessive pressure. Replace and determine cause of pressure.

2. Failure to close: (a) Electrical control is not breaking circuit properly. Check wiring and controls. (b) There are chips of dirt on the PTFE seat and leakage is occurring. To inspect the seat (after pumping out the system as required) disconnect power source to solenoid coil, remove bonnet-tube assembly, and lift out valve needle and plunger assembly. (c) Removable seat assembly or valve needle may be worn or damaged and therefore leaking. After disassembling valve, as outlined in (2b) above, seat assembly can be removed with a 7/16" socket having a maximum O.D. of 21/32". If either the needle or seat is worn or damaged, replacement of both plunger needle assembly and seat assembly is recommended. As seat assembly has a knife edge seal, gasket is not required. Thoroughly clean all parts and reassemble. (d) Manual opening stem is turned all or partly in, holding valve needle open and permitting flow through valve. (e) Coil housing screw (made of non-magnetic stainless steel) has been replaced with a screw made of a magnetic material and residual magnetism is holding valve needle and plunger assembly in the open position. Replace with a screw of correct material.

3. Leakage through valve: See (2) above.

4. Coil Temperature: The solenoid coil is designed to operate hot, and is constructed of high temperature materials. Accordingly, unless troubled with actual coil burnouts, high coil temperature should be ignored. Persistent burnouts indicate improper line or coil voltage. See "Electrical".

Warranty

All Refrigerating Specialties Products are warranted against defect in workmanship and materials for a period of one year from date of shipment from originating factory. This warranty is in force only when products are properly installed, field assembled, maintained and operated in use and service as specifically stated in Refrigerating Specialties Catalogs or Bulletins for normal refrigeration applications, unless otherwise approved in writing by Refrigerating Specialties Division. Defective products, or parts thereof, returned to the factory with transportation charges prepaid and found to be defective by factory inspection will be replaced or repaired at Refrigerating Specialties' option, free of charge, F.O.B. factory. Warranty does not cover products which have been altered, repaired in the field; damaged in transit, or have suffered accidents, misuse, or abuse. Products disabled by dirt, or other foreign substances will not be considered defective.

THE EXPRESS WARRANTY SET FORTH ABOVE CONSTITUTES THE ONLY WARRANTY APPLICABLE TO REFRIGERATING SPECIALTIES PRODUCTS, AND IS IN LIEU OF ALL OTHER WARRANTIES, EXPRESS OR IMPLIED, WRITTEN OR ORAL, INCLUDING ANY WARRANTY OF MERCHANTABILITY, OR FITNESS FOR A PARTICULAR PURPOSE. No employee, agent, dealer or other person is authorized to give any warranties on behalf of Refrigerating Specialties, nor to assume, for Refrigerating Specialties, any other liability in connection with any of its products.

Safe Operation

(see also Bulletin RSBCV)

People doing any work on a refrigeration system must be qualified and completely familiar with the system and the Refrigerating Specialties Division valves involved, or all other precautions will be meaningless. This includes reading and understanding pertinent Refrigerating Specialties Division Product Bulletins, and Safety Bulletin RSB prior to installation or servicing work.

Where cold refrigerant liquid lines are used, it is necessary that certain precautions be taken to avoid damage which could result from liquid expansion. Temperature increase in a piping section full of solid liquid will cause high pressure due to the expanding liquid which can possibly rupture a gasket, pipe or valve. All hand valves isolating such sections should be marked, warning against accidental closing, and must not be closed until the liquid is removed. Check valves must never be installed upstream of solenoid valves, or regulators with electric shut-off, nor should hand valves upstream of solenoid valves or downstream of check valves be closed until the liquid has been removed. It is advisable to properly install relief devices in any section where liquid expansion could take place.

Avoid all piping or control arrangements which might produce thermal or pressure shock.

For the protection of people and products, all refrigerant must be removed from the section to be worked on before a valve, strainer, or other device is opened or removed.

Flanges with ODS connections are not suitable for ammonia service.