

DEPTH TRACKER

Liquid Level Transducer Probe
for use with Ammonia
Type ITPB, ITPD, ITPR

FEATURES

- Digital local or remote read-out options.
- Optional display riser accommodates column insulation
- Unique probeelok connection option
- Probe lengths: 2, 3, 4, 5, 6, 7, 8, 10 & 12 foot
- Integrated construction achieved by molding the PTFE sleeve directly to the center rod.
- Electrical connection via 3/4" conduit boss or jacketed communications cable of suitable temperature/ moisture protection.
- Fully potted circuit board.
- Factory pre-calibrated for ammonia for 0-100% level output in 4" IPS Standpipe. The electronics may be re-calibrated in the field to permit viewing of liquid level over any segment representing more than 40% of the probe's overall length.
- All wetted parts are stainless steel construction to prevent corrosion.

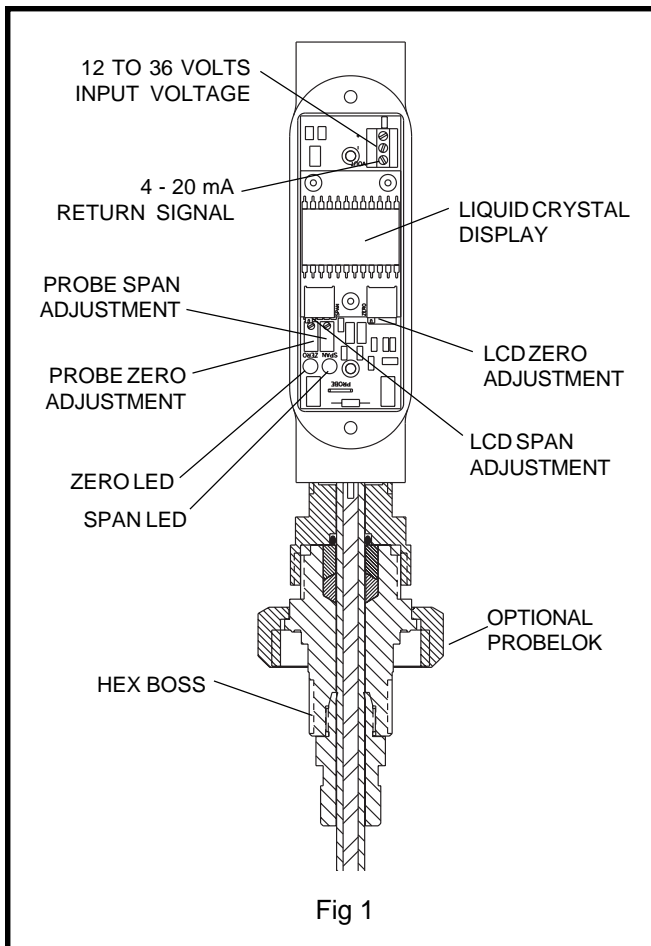

Fig 1

BULLETIN 61-30A
TYPE ITPD, ITPB, ITPR



June, 2002

Installation, Service and Parts Information

Description

Refrigerating Specialties Division has developed multiple lengths of transducer type, liquid level probes for use with ammonia

Focused directly on large vessels and central plant construction, the application supports remote vessel monitoring, performance and charge management, and troubleshooting via a central microprocessor-based control panel.

These capacitance based probes interpret liquid level in a receiver, accumulator or similar pressure vessel as an adjustable current range of 4 to 20 mA. when powered by an 12 to 36V. DC regulated remote source.

The signal is proportional to the vertical liquid level surrounding the probe. The probe is mounted, sealed and grounded electrically via a 3/4" MPT thread installed into the top cap of a standpipe column. An available surrounding, steel sleeve reinforces and protects the probe while providing repeatability and precision output irrespective of vessel design.

Purpose

The Type ITP Liquid Level Transducer Probe is used to provide a current signal proportional to the vertical liquid level. A remote controller (PLLC) or microprocessor functioning as a switching mechanism can convert the signal transmitted. This device is for use with refrigerant R-717 ammonia only. It may be used with liquid temperatures in a range of -107° to 135° F. The minimum ambient for circuit board enclosure is -20° F.

Safe Operation (See also Bulletin RSB)

Installation

PIPE COLUMN

The Pipe Column should be installed as shown in Fig 3. The position and orientation of the column must be appropriate to the specific application and installation criteria. The Pipe Column must always be in a vertical position. In any case, it must be in a serviceable location and out of the way of any possible damage by material handling vehicles such as lift trucks.

It is important to have several sight glasses well spaced along the height of the Pipe Column to determine the level of the liquid when setting the ITPB as well as to check its performance during operation of the system. These are an essential part of any well designed pressure vessel system and the use of an electronic liquid level control does not eliminate this need.

The pipe connection at the top of the Pipe Column equalizing the vapor spaces must be well above the highest switch point on the vessel upon which it is to be mounted. The piping for this line should never be trapped, as any liquid in such a trap can cause the Pipe Column to become vapor bound.

The liquid equalizing line at the bottom of the Pipe Column must be well below the lowest switch point level on the vessel on which it is to be mounted. This line

must be free draining and offer no obstruction to a gravity flow of liquid. It should not be trapped, particularly on an Ammonia system, as it would then become an ideal location for oil to accumulate and could cause false levels in the Pipe Column. It is recommended that a drain connection be installed at the low point on the Pipe Column so that the Pipe Column can be drained when service is required. Both the vapor and the liquid equalizer lines should be as short as possible.

To select the proper probe size, the pipe column height and fitting should be known. Subtract the value of the minimum clearance from the probe bottom plus the typical engagement length from the vessel height to determine the maximum insertion length. Actual probe insertion length may be less than maximum length allowed. Probe insertion length must be long enough to measure the lowest receiver level desired. Probe lengths are not field adjustable.

Probe location should allow for adequate installation and removal without bending. Avoid locating near liquid inlet to receiver. The probe location should not interfere with dip tubes or other internal parts.

Heat will readily cause a volatile liquid, such as a refrigerant to boil. Thus it is important to impede the transference of heat to a cold refrigerant whose level is being measured. A cold liquid refrigerant contained in an

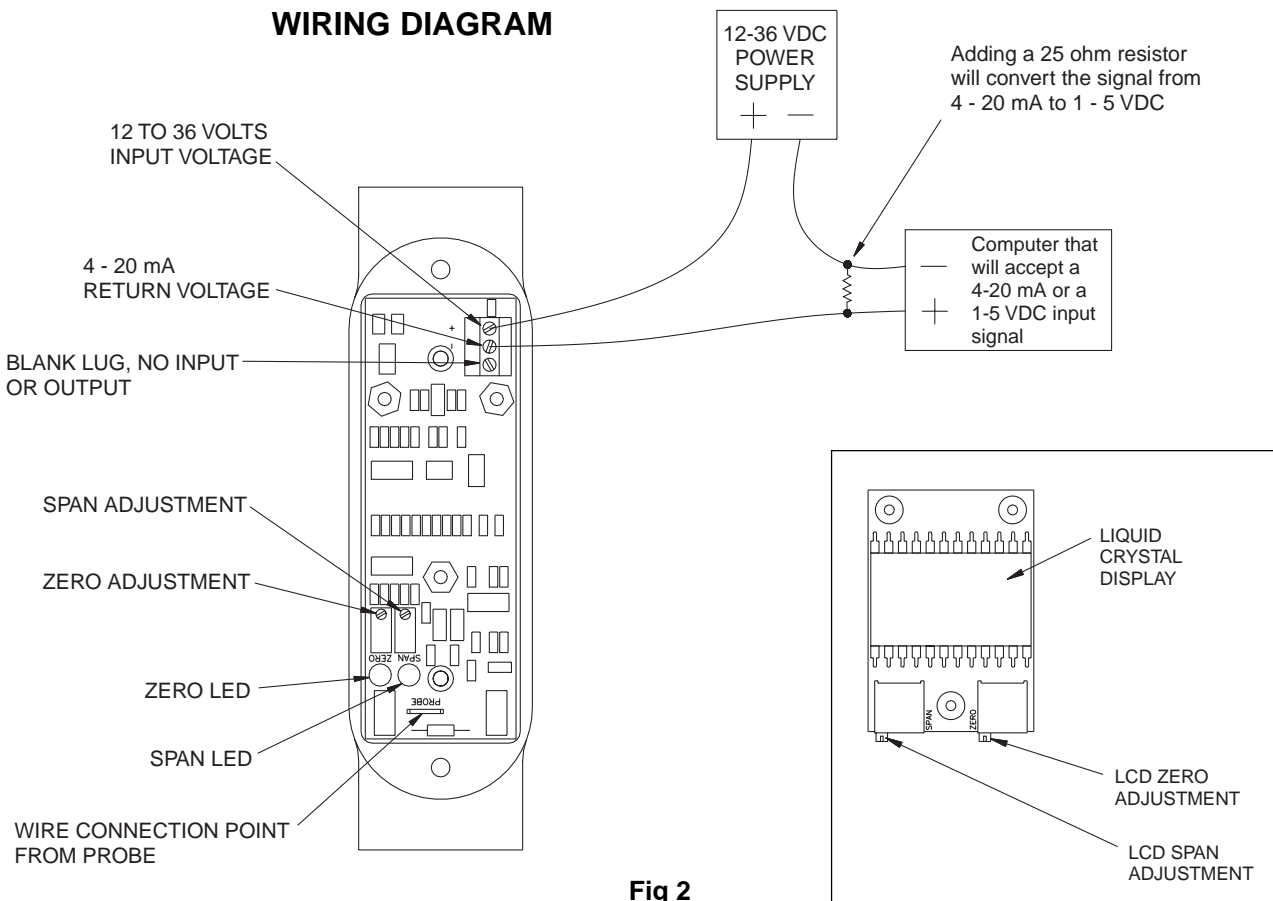

Fig 2

uninsulated pipe column that is located in a warm compressor room is a good example of an improper installation. It is important to properly insulate the pipe column and to use 4" (100mm) pipe which will reduce the ratio of the pipe surface area to its internal volume. The larger the pipe size the smaller will be this ratio and the less will be the tendency to boil refrigerant inside the

pipe. 4" (100 mm) pipe is the preferred size, but in many cases (particularly where there is a relatively small temperature difference between the liquid and the ambient space), a 3" (75 mm) size should result in proper performance.

Caution: Grip and tighten probe on hex boss only. Do not grip circuit board housing.

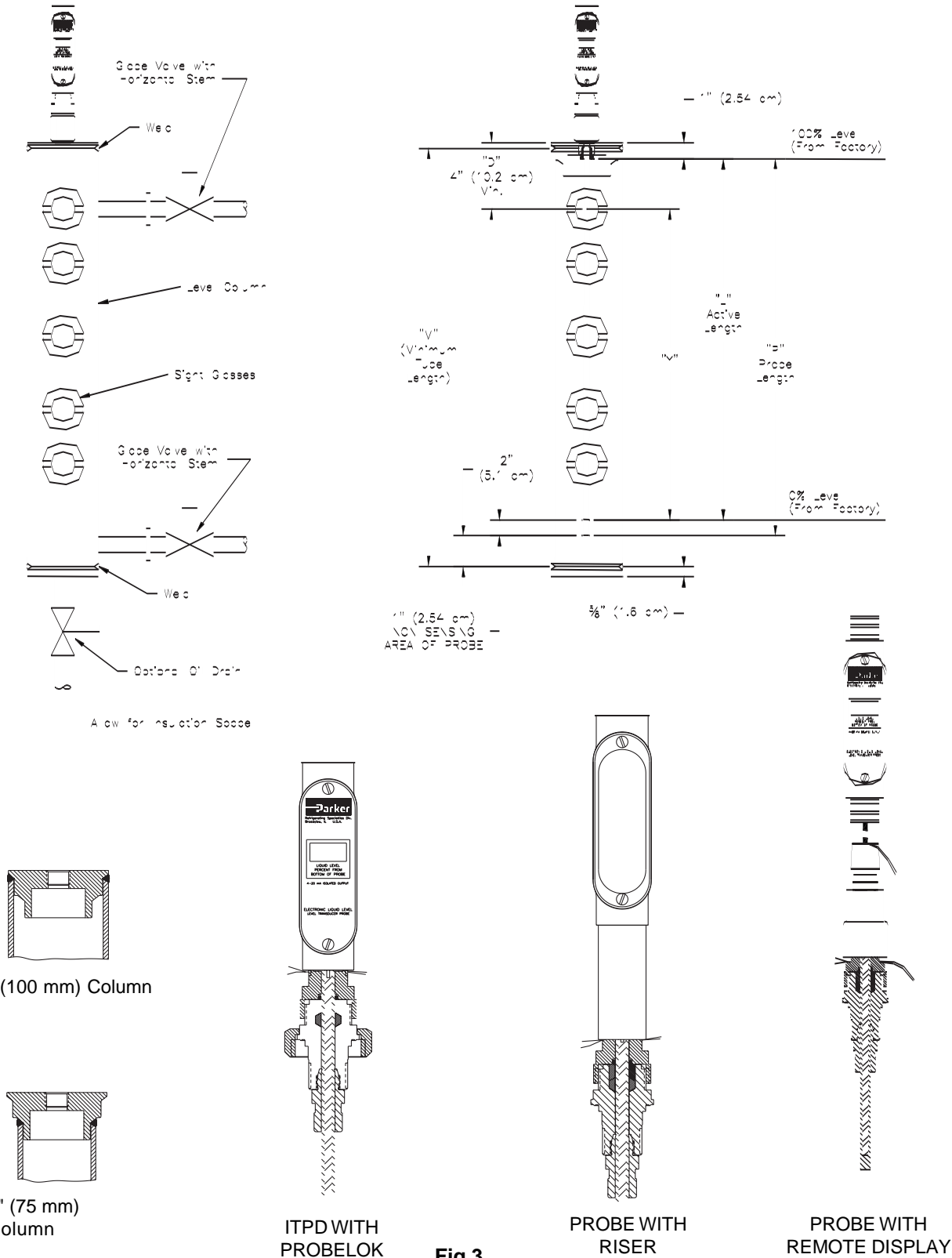

Fig 3

Electrical

Run wiring through 3/4" NPT electrical opening on top of enclosure. Wiring should be at minimum 20 AWG. To protect electronics from moisture, dirt, etc., seal the electrical opening with a watertight cable connector or if a Conduit Fitting is used, install conduit laterally lower than electrical housing on probe and seal conduit with Silicone Sealant immediately above probe. . To prevent electrical noise, it is important not to run wires with or near power wires.

Calibration

All probes are pre-calibrated at the factory for a Ammonia. Shielded probes with steel sleeves should not require field adjustment unless only a segment of the probe is represented or something other than a 4" standpipe column is used. Probe can be calibrated using the optional Liquid Crystal Display or by putting a voltmeter in the circuit set to read Milliamps (or DC Volts if the 250 ohm resistor is used). To calibrate, disconnect probe from controller or computer. Install voltmeter in series with output of control loop. Lower refrigerant level in receiver to a level equal to 0% and the zero LED is on; the voltmeter should display 0.0 Milliamps. For probes with Liquid Crystal Display set LCD zero adjustment accordingly . Raise the liquid level in the receiver to the 50% level or some other known level. The voltmeter should display 12 Milliamps for a 50% probe immersion level. For other levels the corresponding equivalent amperage should be displayed. If not adjust the probe span adjustment screw. For probes with Liquid Crystal Display set LCD span adjustment accordingly.

Safe Operation (See also Bulletin RSB)
People doing any work on a refrigeration system must be qualified and completely familiar with the system and the Refrigerating Specialties Division valves involved, or all other precautions will be meaningless. This includes reading and understanding pertinent Refrigerating Specialties Division product Bulletins and Safety Bulletin RSB prior to installation or servicing work.

Where cold refrigerant liquid lines are used, it is necessary that certain precautions be taken to avoid damage that could result from liquid expansion. Temperature increase in a piping section full of solid liquid will cause high pressure due to the expanding liquid that can possibly rupture a gasket, pipe or valve. All hand valves

isolating such sections should be marked, warning against accidental closing, and must not be closed until the liquid is removed. Check valves must never be installed upstream of solenoid valves, or regulators with electric shut-off, nor should hand valve upstream of solenoid valves or downstream of check valves be close until the liquid has been removed. It is advisable to properly install relief devices in any section where liquid expansion could take place.

Avoid all piping or control arrangements that might produce thermal or pressure shock. For the protection of people and products, all refrigerant must be removed from the section to be worked on before a valve, strainer, or other device is opened or removed. Flanges with ODS connections are not suitable for ammonia service.

Warranty

All Refrigerating Specialties products are warranted against defects in workmanship and materials for a period of one year from date of shipment from originating factory. This warranty is in force only when products are properly installed, field assembled, maintained, and operated in use and service as specifically stated in Refrigerating Specialties Catalogs or Bulletins for normal refrigeration applications, unless otherwise approved in writing by Refrigerating Specialties Division. Defective products, or parts thereof returned to the factory with transportation charges prepaid and found to be defective by factory inspection will be replaced or repaired at Refrigerating Specialties option, free of charge F.O.B. factory. Warranty does not cover products that have been altered, or repaired in the field; damaged in transit, accidents, misuse, or abuse. Products disabled by dirt or other foreign substances will not be considered defective.

The express warranty above constitutes the only warranty of Refrigerating Specialties products, and is in lieu of all other warranties, expressed or implied, written or oral, including any warranty of merchantability or warranty of fitness for a particular purpose and in no event is Refrigerating Specialties responsible for any consequential damages of any nature whatsoever. No employee, agent, dealer or other person is authorized to give any warranties on behalf of Refrigerating Specialties nor to assume for Refrigerating Specialties any other liability in connection with any of its products.